



±15kV ESD-Protected, 1Mbps, 1µA RS-232 Transmitters in SOT23-6

MAX3188E/MAX3189E

General Description

The MAX3188E/MAX3189E single RS-232 transmitters in a SOT23-6 package are for space- and cost-constrained applications requiring minimal RS-232 communications. These devices consume only 150µA of supply current from ±4.5V to ±6V supplies. They feature a shutdown input that reduces current consumption to only 1µA and forces the transmitter output into a high-impedance state. RS-232 data transmission is guaranteed up to 250kbps with the MAX3188E and up to 1Mbps with the MAX3189E.

The MAX3188E/MAX3189E are EIA/TIA-232 transmitters that convert CMOS/TTL logic levels to RS-232-compliant signals. The transmitter output is protected to ±15kV using the IEC 1000-4-2 Air-Gap Discharge method, to ±8kV using the IEC 1000-4-2 Contact Discharge method, and to ±15kV per the Human Body Model, ensuring strict compliance with international standards. The MAX3188E/MAX3189E transmitters have a standard inverting output.

Applications

Diagnostic Ports
Telecommunications
Networking Equipment
Set-Top Boxes
Digital Cameras
Hand-Held Equipment

Typical Operating Circuit

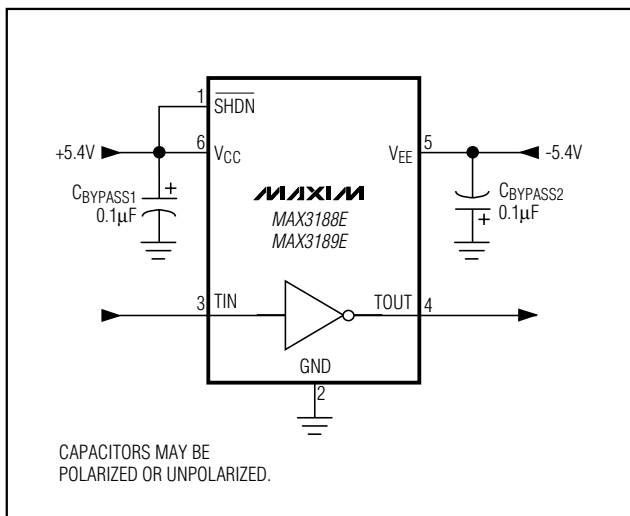

Features

- ◆ Small 6-Pin SOT23 Package
- ◆ ESD-Protected RS-232 Output
 - ±15kV per Human Body Model
 - ±8kV per IEC 1000-4-2, Contact Discharge
 - ±15kV per IEC 1000-4-2, Air-Gap Discharge
- ◆ 150µA Operating Supply Current
- ◆ Shutdown Reduces Supply Current to 1µA
- ◆ Guaranteed Data Rate
 - 1Mbps (MAX3189E)
 - 250kbps (MAX3188E)
- ◆ Three-State RS-232 Transmitter Output
- ◆ No External Components

Ordering Information

PART	TEMP. RANGE	PIN-PACKAGE	TOP MARK
MAX3188EEUT-T	-40°C to +85°C	6 SOT23-6	AAHD
MAX3189EEUT-T	-40°C to +85°C	6 SOT23-6	AAHE

Pin Configuration

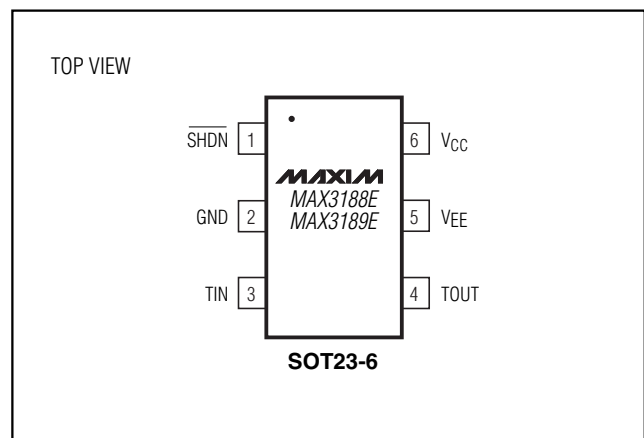

±15kV ESD-Protected, 1Mbps, 1µA RS-232 Transmitters in SOT23-6

ABSOLUTE MAXIMUM RATINGS

V _{CC} to GND (Note 1).....	-0.3V to +7V	Continuous Power Dissipation (T _A = +70°C)	
V _{EE} to GND (Note 1).....	+0.3V to -7V	6-Pin SOT23 (derate 8.7mW/°C above +70°C).....	691mW
V _{CC} to V _{EE} (Note 1).....	+13V	Operating Temperature Range	-40°C to +85°C
TIN, SHDN to GND.....	-0.3V to +7V	Junction Temperature	+150°C
TOUT to GND (SHDN = GND).....	±13.2V	Storage Temperature Range	-65°C to +150°C
TOUT to GND (SHDN = V _{CC}).....	±7V	Lead Temperature (soldering, 10s)	+300°C
Output Short-Circuit Duration.....	Continuous		

Note 1: V_{CC} and V_{EE} can have maximum magnitudes of 7V, but their absolute difference cannot exceed 13V.

Stresses beyond those listed under "Absolute Maximum Ratings" may cause permanent damage to the device. These are stress ratings only, and functional operation of the device at these or any other conditions beyond those indicated in the operational sections of the specifications is not implied. Exposure to absolute maximum rating conditions for extended periods may affect device reliability.

ELECTRICAL CHARACTERISTICS

(V_{CC} = +4.5V to +6V, V_{EE} = -4.5V to -6V, T_A = T_{MIN} to T_{MAX}, unless otherwise noted. Typical values are at V_{CC} = +5.4V, V_{EE} = -5.4V, and T_A = +25°C.) (Note 2)

PARAMETER	SYMBOL	CONDITIONS	MIN	TYP	MAX	UNITS
DC CHARACTERISTICS						
Positive Supply Voltage	V _{CC}		4.5		6	V
Negative Supply Voltage	V _{EE}		-6		-4.5	V
Positive Supply Current	I _{CC}	V _{SHDN} = 5V			170	µA
Negative Supply Current	I _{EE}	V _{SHDN} = 5V	45			µA
Shutdown Supply Current		V _{SHDN} = 0		0.2	1	µA
INPUT LOGIC (TIN, SHDN)						
Input Logic Threshold Low	V _{IL}				0.8	V
Input Logic Threshold High	V _{IH}		2.0			V
Input Leakage				±0.01	±1	µA
TIN Input Hysteresis				100		mV
TRANSMITTER OUTPUTS						
Output Voltage Swing	V _{TOUT}	V _{CC} = 4.5V, V _{EE} = -4.5V, R _L = 3kΩ	±3.7			V
		V _{CC} = 5.4V, V _{EE} = -5.4V, R _L = 3kΩ	±5			
Output Resistance	R _{TOUT}	V _{CC} = V _{EE} = 0, V _{TOUT} = ±2V	300			Ω
Output Short-Circuit Current				±35	±60	mA
Output Leakage Current	I _{TOUT}	V _{OUT} = ±12V; V _{CC} = V _{EE} = 0 or V _{CC} = 5.4V, V _{EE} = -5.4V; SHDN = 0			±25	µA
TIMING CHARACTERISTICS						
Maximum Data Rate		R _L = 3kΩ, C _L = 1000pF	MAX3188E	0.25		Mbps
			MAX3189E	1		
Transmitter Skew	t _{TS}	t _{PHL} - t _{PLH} , Figure 1	MAX3188E	100		ns
			MAX3189E	25		
Transition-Region Slew Rate		R _L = 3kΩ to 7kΩ, C _L = 150pF to 1000pF, measured from -3V to +3V or +3V to -3V, V _{CC} = 5.4V, V _{EE} = -5.4V, T _A = +25°C	MAX3188E	6	30	V/µs
			MAX3189E	24	150	
Transmitter Enable Time	t _{EN}			2		µs

$\pm 15\text{kV}$ ESD-Protected, 1Mbps, 1 μA RS-232 Transmitters in SOT23-6

MAX3188E/MAX3189E

ELECTRICAL CHARACTERISTICS (continued)

($V_{CC} = +4.5\text{V}$ to $+6\text{V}$, $V_{EE} = -4.5\text{V}$ to -6V , $T_A = T_{MIN}$ to T_{MAX} , unless otherwise noted. Typical values are at $V_{CC} = +5.4\text{V}$, $V_{EE} = -5.4\text{V}$, and $T_A = +25^\circ\text{C}$.) (Note 2)

PARAMETER	SYMBOL	CONDITIONS	MIN	TYP	MAX	UNITS
ESD PROTECTION						
TOUT		IEC 1000-4-2 Air-Gap Discharge		± 15		kV
		IEC 1000-4-2 Contact Discharge		± 8		
		Human Body Model		± 15		

Note 2: All devices are 100% tested at $T_A = +25^\circ\text{C}$. All limits over temperature are guaranteed by design.

Typical Operating Characteristics

($V_{CC} = +5.4\text{V}$, $V_{EE} = -5.4\text{V}$, $R_L = 3\text{k}\Omega$, $T_A = +25^\circ\text{C}$, unless otherwise noted.)

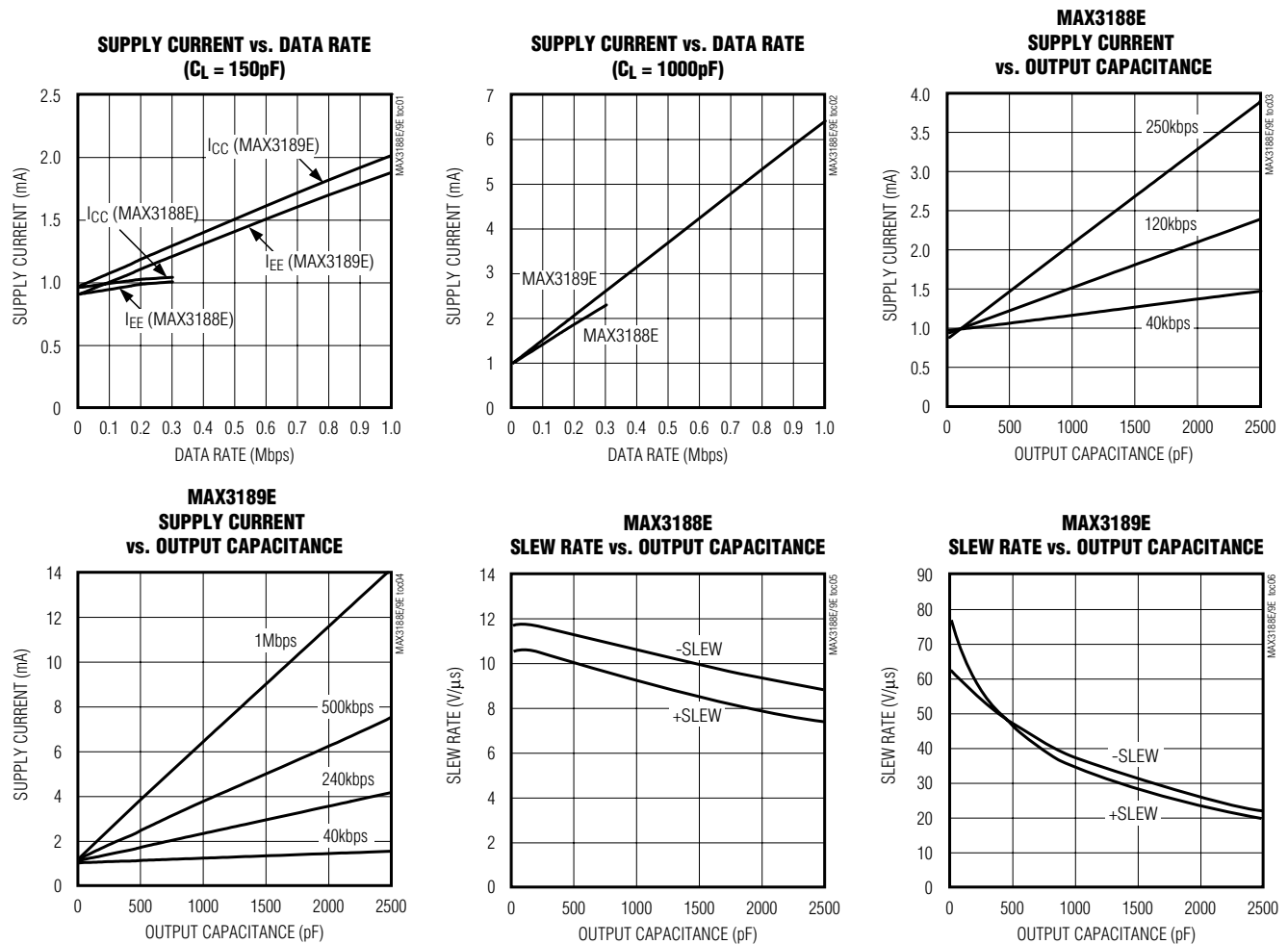

±15kV ESD-Protected, 1Mbps, 1µA RS-232 Transmitters in SOT23-6

Typical Operating Characteristics (continued)

(V_{CC} = +5.4V, V_{EE} = -5.4V, R_L = 3kΩ, T_A = +25°C, unless otherwise noted.)

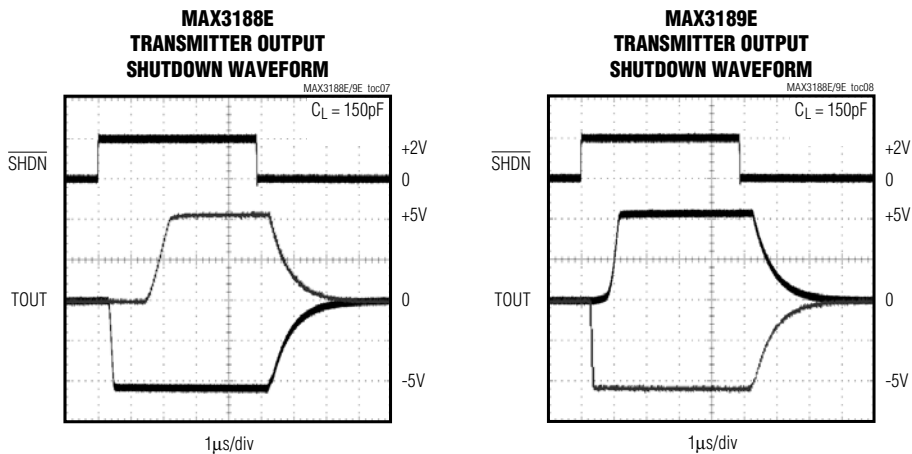

Pin Description

PIN	NAME	FUNCTION
1	$\overline{\text{SHDN}}$	Active-Low Shutdown. Pull low to reduce the supply current and to force TOUT into a high-impedance state.
2	GND	Ground
3	TIN	TTL/CMOS Transmitter Input
4	TOUT	RS-232 Transmitter Output
5	V _{EE}	Negative Supply Voltage
6	V _{CC}	Positive Supply Voltage

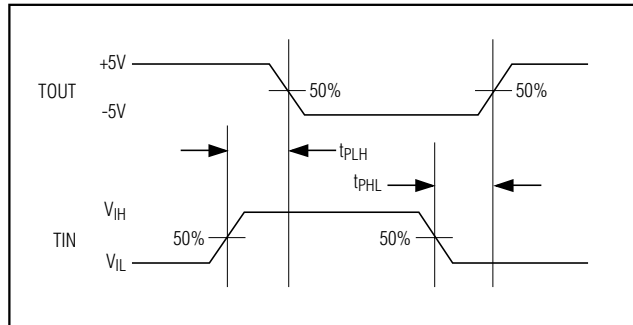

Figure 1. Transmitter Propagation-Delay Timing

Detailed Description

The MAX3188E/MAX3189E are EIA/TIA-232 transmitters that convert CMOS/TTL logic levels to RS-232 signals. They operate on ±4.5V to ±6V supplies and feature enhanced electrostatic discharge protection (see *ESD Protection*). The MAX3188E guarantees a 250kbps data rate, and the MAX3189E guarantees a 1Mbps data rate with worst-case loads of 3kΩ in parallel with 1000pF. The MAX3188E/MAX3189E invert the TOUT signal relative to TIN (standard RS-232). The transmitter input does not have a pull-up resistor and should be connected to GND if unused.

Shutdown

The MAX3188E/MAX3189E feature a shutdown input. Drive $\overline{\text{SHDN}}$ low to reduce the supply current to 1µA (max). Shutdown also forces TOUT into a high-impedance state, allowing the signal line to be safely controlled by other transmitters. Drive $\overline{\text{SHDN}}$ high for normal operation.

ESD Protection

As with all Maxim devices, ESD protection structures are incorporated on all pins to protect against ESD encountered during handling and assembly. The MAX3188E/MAX3189Es' transmitter output has extra protection against static electricity. Maxim has developed state-of-the-art structures enabling this pin to withstand ESD up

±15kV ESD-Protected, 1Mbps, 1µA RS-232 Transmitters in SOT23-6

to ±15kV without damage or latch-up. The MAX3188E/MAX3189E's transmitter output is characterized for protection to the following limits:

- ±15kV using the Human Body Model
- ±8kV using the Contact Discharge method specified in IEC 1000-4-2
- ±15kV using the Air-Gap Discharge method specified in IEC 1000-4-2

Human Body Model

Figure 2 shows the Human Body Model, and Figure 3 shows the current waveform it generates when discharged into a low impedance. This model consists of a 100pF capacitor charged to the ESD voltage of interest, and then discharged into the test device through a 1.5kΩ resistor.

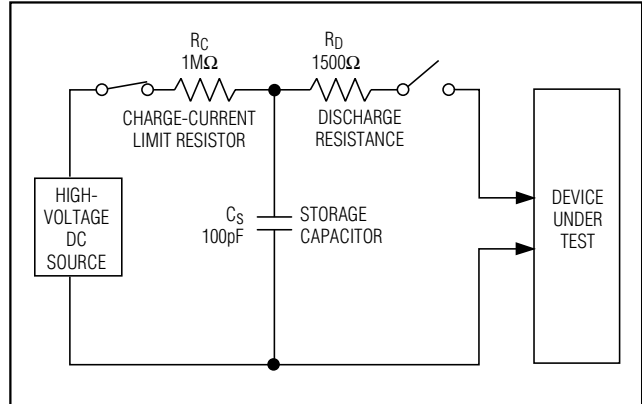

Figure 2. Human Body ESD Test Model

IEC 1000-4-2

The IEC 1000-4-2 standard covers ESD testing and performance of finished equipment; it does not specifically refer to ICs. The MAX3188E/MAX3189E enable the design of equipment that meets the highest level (Level 4) of IEC 1000-4-2 without the need for additional ESD-protection components. The major difference between tests done using the Human Body Model and IEC 1000-4-2 is higher peak current in IEC 1000-4-2. Because series resistance is lower in the IEC 1000-4-2 model, the ESD withstand voltage measured to this standard is generally lower than that measured using the Human Body. Figure 4 shows the IEC 1000-4-2 model, and Figure 5 shows the current waveform for the ±8kV IEC 1000-4-2 Level 4 ESD Contact Discharge test. The Air-Gap test involves approaching the device with a charged probe. The Contact Discharge method connects the probe to the device before the probe is energized.

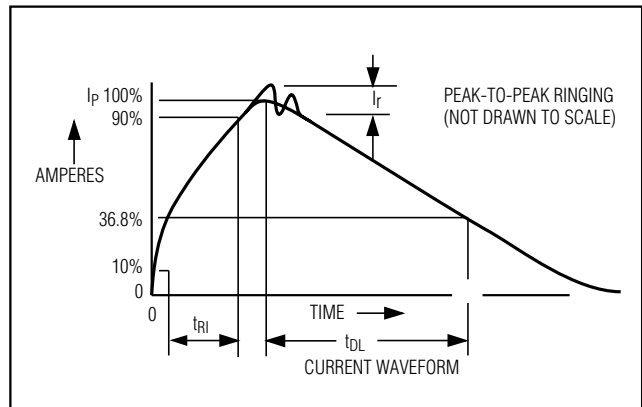

Figure 3. Human Body Model Current Waveform

Power-Supply Decoupling

In most circumstances, 0.1µF bypass capacitors are adequate for power-supply decoupling. Connect the bypass capacitors as close to the IC as possible.

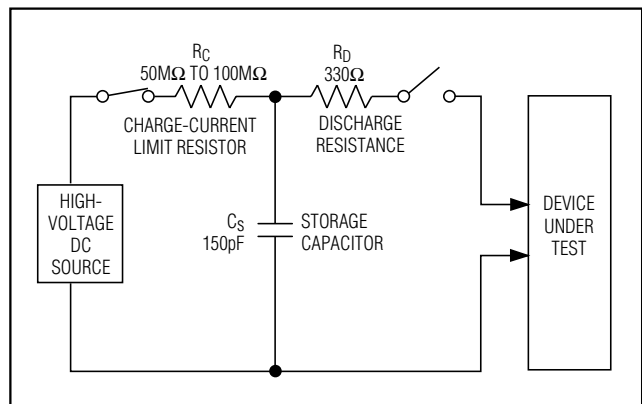

Figure 4. IEC 1000-4-2 ESD Test Model

±15kV ESD-Protected, 1Mbps, 1µA RS-232 Transmitters in SOT23-6

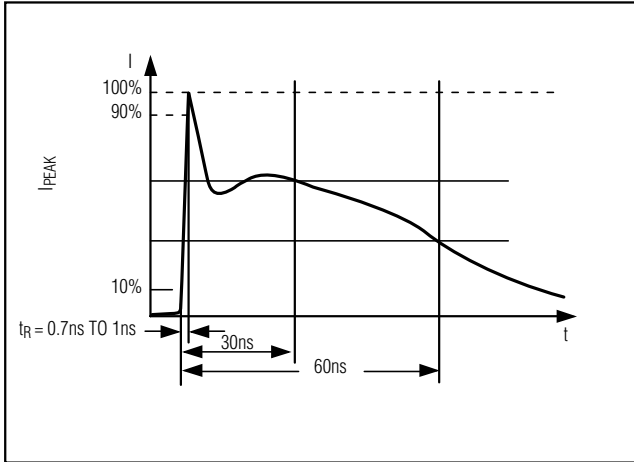

Figure 5. IEC 1000-4-2 ESD Generator Current Waveform

Applications Information

Power-Supply Sources

The MAX3188E/MAX3189E require ±4.5V to ±6V dual supplies. For applications where these supply voltages are not present, a DC-DC converter must be added. Due to the MAX3188E/MAX3189Es' low current consumption, a charge pump can provide the proper supply voltages and requires a minimal amount of board space and cost.

When using another RS-232 device containing an internal regulated charge pump (Table 1), the MAX3188E/MAX3189E may be powered from the internal charge pump (Figure 6). This eliminates the need for additional external DC-DC converters to generate the required ±4.5V to ±6V dual supplies.

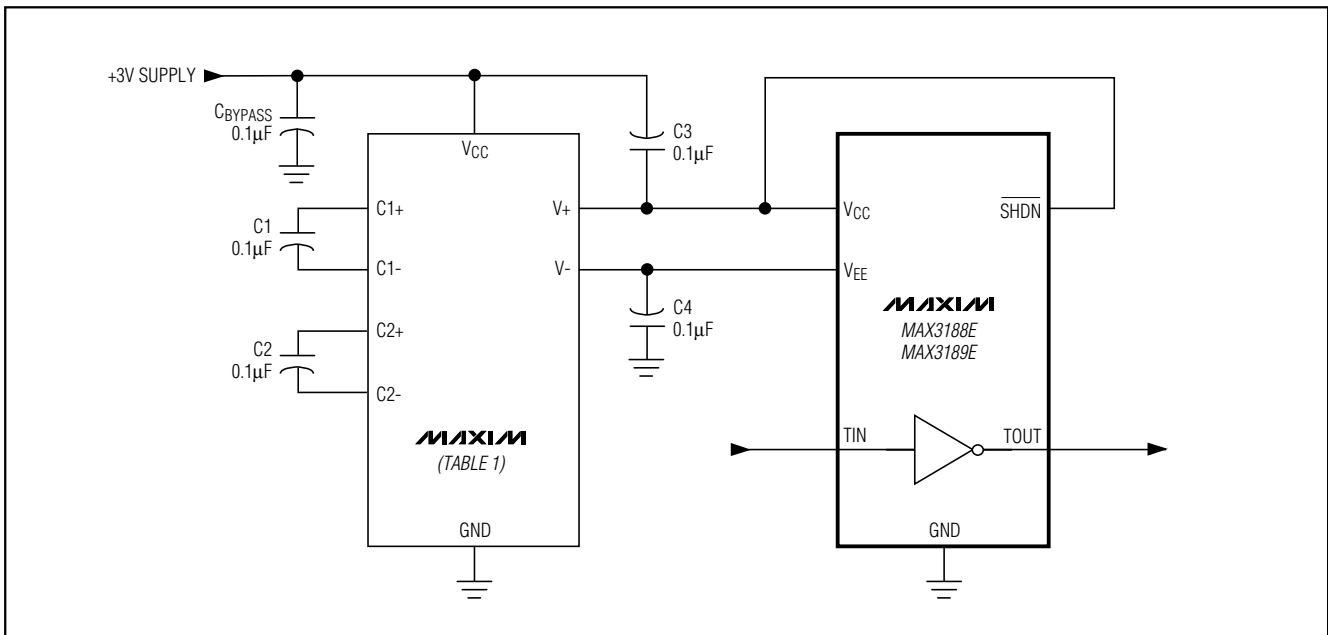

Figure 6. Powering the MAX3188E/MAX3189E

±15kV ESD-Protected, 1Mbps, 1µA RS-232 Transmitters in SOT23-6

MAX3188E/MAX3189E

Table 1. RS-232 Devices with Internal Regulated Charge Pumps

PART	NO. OF Tx/Rx	±15kV ESD PROTECTION	AutoShutdown Plus™	AutoShutdown™	DATA RATE (bps)
MAX3221	1/1			✓	120k
MAX3221E	1/1	✓		✓	250k
MAX3222	2/2				120k
MAX3222E	2/2	✓			250k
MAX3223	2/2			✓	120k
MAX3223E	2/2	✓		✓	250k
MAX3224	2/2		✓		250k
MAX3224E	2/2	✓	✓		250k
MAX3225	2/2		✓		1M
MAX3225E	2/2	✓	✓		1M
MAX3226	1/1		✓		250k
MAX3226E	1/1	✓	✓		250k
MAX3227	1/1		✓		1M
MAX3227E	1/1	✓	✓		1M
MAX3232	2/2				120k
MAX3232E	2/2	✓			250k
MAX3237	5/3				1M
MAX3238	5/3		✓		250k
MAX3241	3/5				120k
MAX3241E	3/5	✓			250k
MAX3243	3/5			✓	120k
MAX3243E	3/5	✓		✓	250k
MAX3244	3/5		✓		250k
MAX3244E	3/5	✓	✓		250k
MAX3245	3/5		✓		1M
MAX3245E	3/5	✓	✓		1M

Chip Information

TRANSISTOR COUNT: 111

AutoShutdown and AutoShutdown Plus are trademarks of Maxim Integrated Products.

±15kV ESD-Protected, 1Mbps, 1µA RS-232 Transmitters in SOT23-6

Package Information

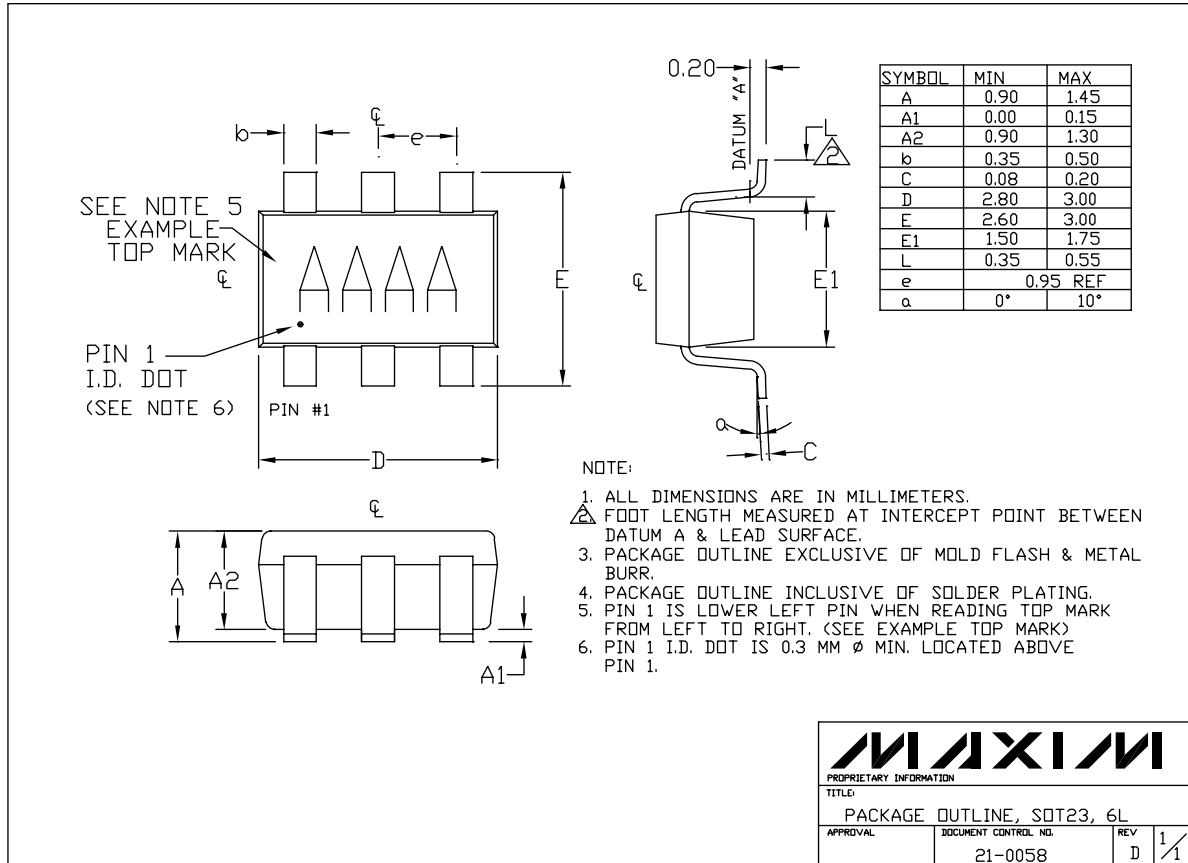

6LSOT23-6

MAXIM

PROPRIETARY INFORMATION

TITLE: PACKAGE OUTLINE, SOT23, 6L

APPROVAL	DOCUMENT CONTROL NO.	REV	1/1
	21-0058	D	

Maxim cannot assume responsibility for use of any circuitry other than circuitry entirely embodied in a Maxim product. No circuit patent licenses are implied. Maxim reserves the right to change the circuitry and specifications without notice at any time.

8 Maxim Integrated Products, 120 San Gabriel Drive, Sunnyvale, CA 94086 408-737-7600